

**IPAPHIPAH®**

# BATTERY PACK **FAST CHARGING**

**NEW 2024**

BATTERY PACK **FAST CHARGING**  
WATCH **THE VIDEO**

**UNIVERSAL CHARGER FOR TABLE**

WIRELESS CHARGER + USB-A + USB-C

# CHARGING NEED IN PUBLIC PLACES

**4<sup>h</sup>**

smartphone  
**daily usage**

**2/3**

want to **charge**  
**their smartphone**  
in HoReCa

LACKING ENERGY?

HERE

CHARGE  
YOUR PHONE

IPATIPAT

HOW  
CAN YOU OFFER  
**DEVICE CHARGING  
SERVICES  
AT THE TABLE ?**

# A STANDALONE POWER SOURCE

with easy installation for all tables



**Easy to install**

No mains connection



**On any table**

Fixed or mobile

# A **MULTI-DEVICE CHARGER**



+

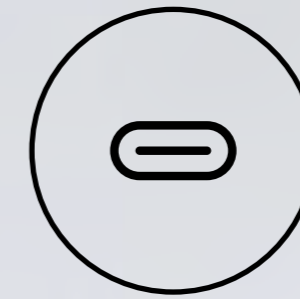

+

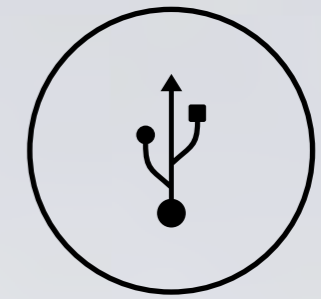

**WIRELESS CHARGER**  
SPOT (x1)

**USB-C**  
SLOT (x1)

**USB-A**  
SLOT (x1)



# FILL UP ON ENERGY

with the “best-in-class” table charger



**15W**



**18W**



**27W**

**IPATIPAT**

# SPECIALLY DESIGNED FOR HORECA OPERATING CONDITIONS

Ultra-strong and handy solutions  
for hassle-free daily use



## **INDOOR & OUTDOOR**

▪ IP65 & shock proof

BATTERY PACK **FAST CHARGING**



## **UP TO 8 DAYS AUTONOMY**

▪ Lithium-ion battery 71Wh



## **ANTI-THEFT SYSTEM**

▪ Magnetic Security Key

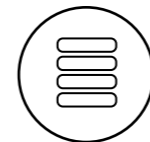

## **FAST CHARGING TRAY**

▪ 4 slots / Full charge in 3h

# WIRELESS CHARGER

3 types of integration



**ON TOP**

UNIVERSAL EASY TO INSTALL SOLUTION



**FLAT**

PERFECT SMOOTH FINISH ON SURFACE



**EMBEDDED**

INTEGRATED WIRELESS CHARGING STATION



# CUSTOM ANTENNA

A new access for your customers to your digital services



## UNIQUE ANTENNA, UNIQUE SERVICE !

- Enhances Branding awareness
- Integrates store design and corporate colors
- Attracts customers and drives them to use the charger for a better in-store experience



ORDERING



PAYMENT



SERVICES



REWARDS



REVIEW



PROMOTION

**IPATIPAT**

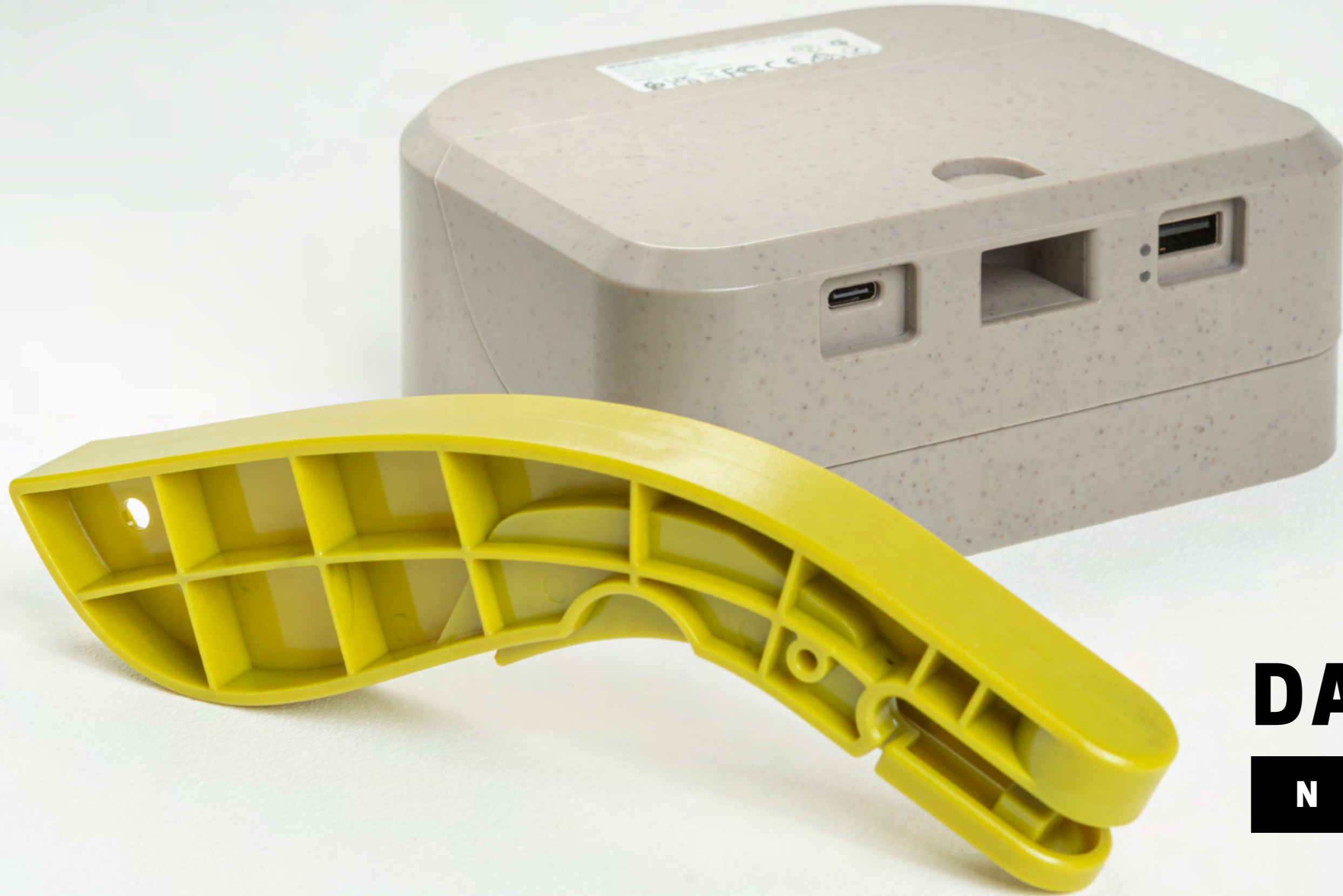

**DATA SHEET**

**NEW 2024**



# ON TOP PACK

PARK NUMBER : **IPN-BPV2/OTP**

## PRODUCT DESCRIPTION

A battery charger for phones and other mobile devices that can be quickly attached to all types of furniture thanks to its ultra-resistant adhesive. The On Top antenna is installed in a drill hole, it is waterproof and UV resistant. Its aluminium finish highlights the charging area while combining finesse and robustness.

## FEATURES



Installation in **10 mins**



1 single hole of **3mm min.**

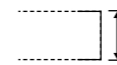

Top thickness from **8 to 55 mm**

## TECH SPECS

- Model number: IPN-BPV2
- FCC ID : 2A06R-IPN-BPV2
- Safe: overheating, overcurrent, overvoltage and short circuit protection
- Type: Wireless & USB (type A & type C) chargers on battery
- Charges: Up to 4 devices
- Outputs: USB-A : 18W Max, USB-C: Power Delivery 27W Max, DC-OUT : 24W Max.
- Inputs: DC-IN : 18W Max, USB-C : Power Delivery 27W Max
- Qi Wireless Charging: wireless charger works with all Qi compatible devices
- Pack dimensions (LxWxH): 22 x 11 x 13,5 cm
- Pack net weight: 900 gr

## WHAT'S IN THE BOX

- On top antenna
- Table Dock
- Lithium-ion Battery (71 Wh)

*Magnetic security key and Charging Tray sold separately.*

## CERTIFICATIONS



## BATTERY PACK **FAST CHARGING**

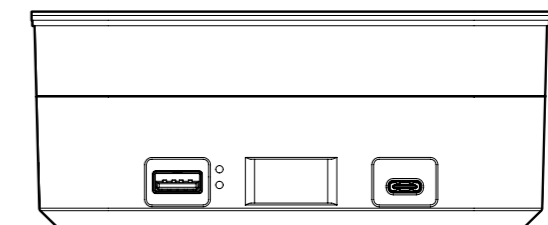
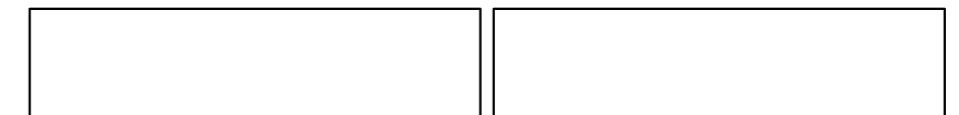
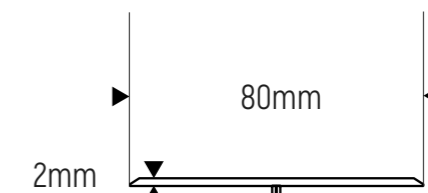
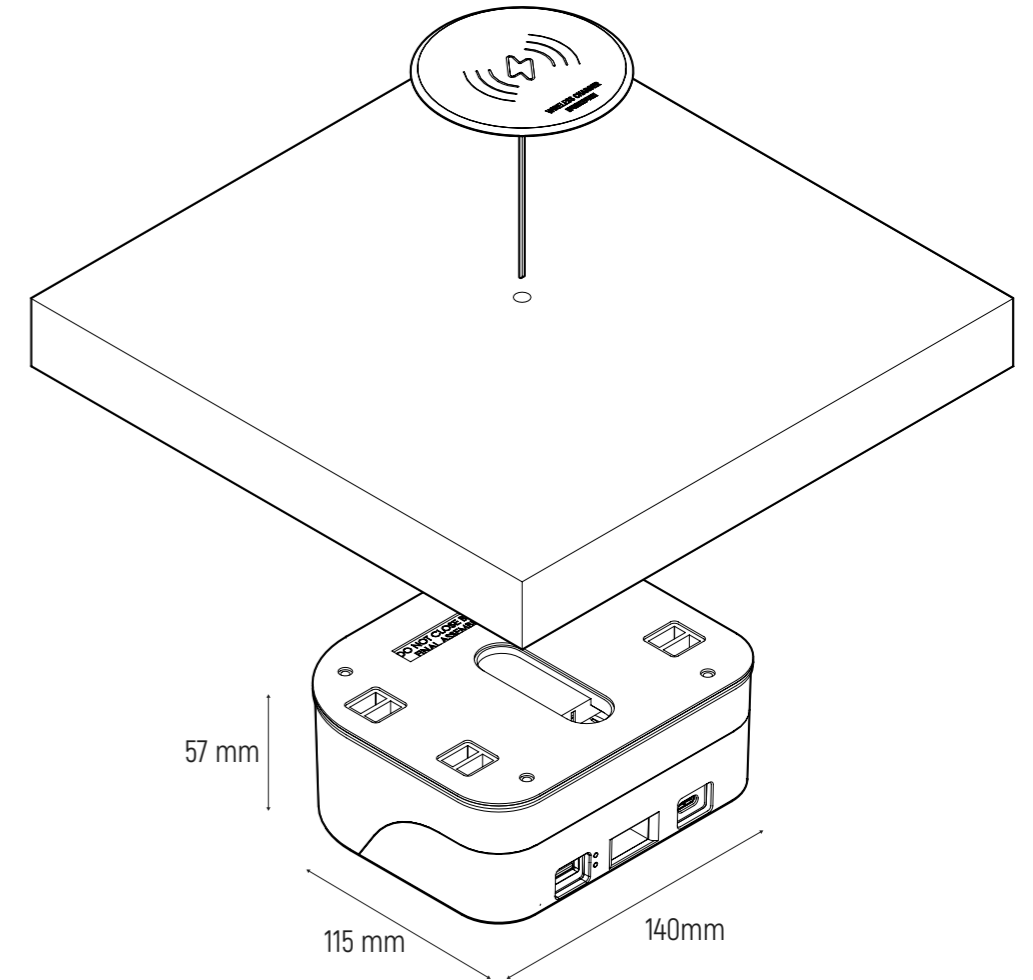



# FLAT PACK

PARK NUMBER : **IPN-BPV2/FLT**

## PRODUCT DESCRIPTION

Perfect condensed between design and sobriety, the flat charging stations are integrated into the table tops' surface to live in perfect harmony with the furniture. These charging stations create a totally flat appearance with the best level of finish that has never been achieved before.

## FEATURES



Flat design



Top thickness from **8 to 60 mm**

## TECH SPECS

- Model number: IPN-BPV2
- FCC ID : 2A06R-IPN-BPV2
- Safe: overheating, overcurrent, overvoltage and short circuit protection
- Type: Wireless & USB (type A & type C) chargers on battery
- Charges: Up to 4 devices
- Outputs: USB-A : 18W Max, USB-C: Power Delivery 27W Max, DC-OUT : 24W Max.
- Inputs: DC-IN : 18W Max, USB-C : Power Delivery 27W Max
- Qi Wireless Charging: wireless charger works with all Qi compatible devices
- Pack dimensions (LxWxH): 22 x 11 x 13,5 cm
- Pack net weight: 900 gr

## WHAT'S IN THE BOX

- Flat antenna
- Table Dock
- Lithium-ion Battery (71 Wh)

*Magnetic security key and Charging Tray sold separately.*

## CERTIFICATIONS



## BATTERY PACK **FAST CHARGING**

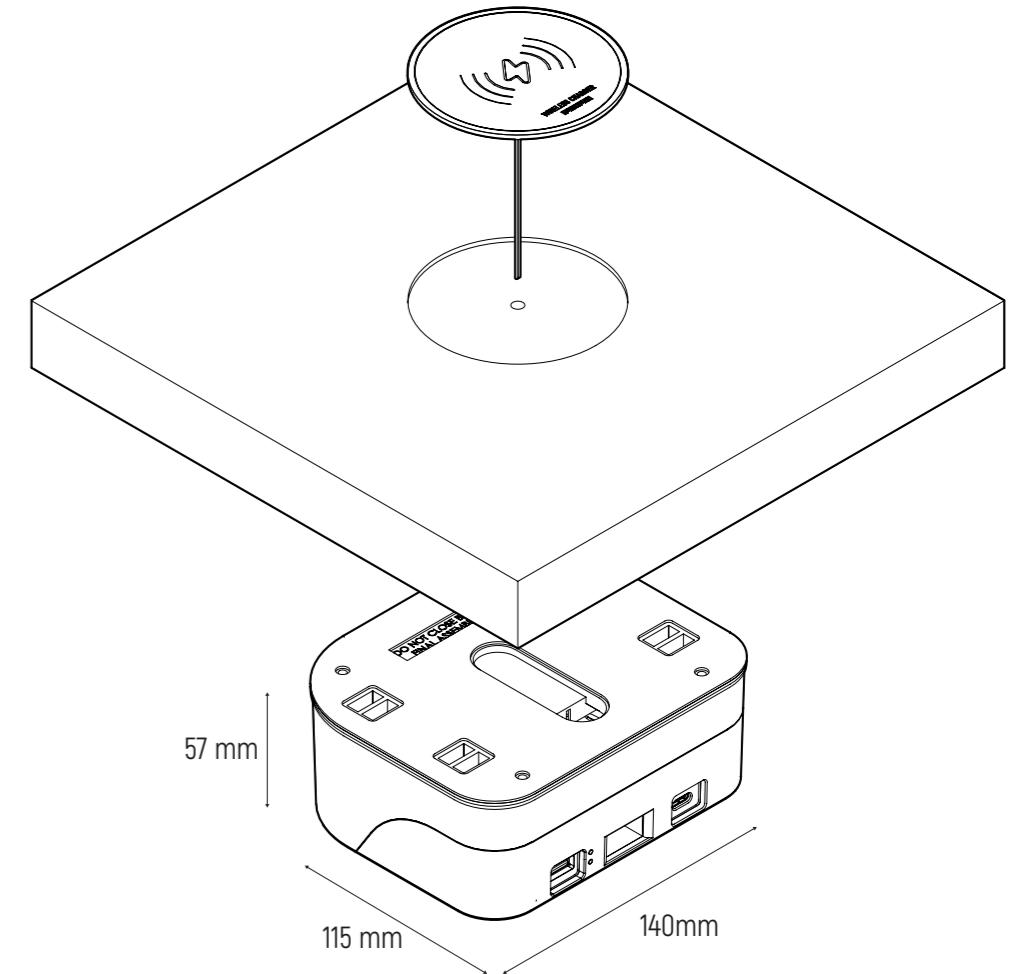

57 mm

115 mm

140mm

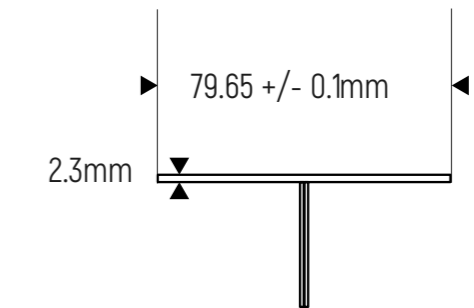

79.65 +/- 0.1mm

2.3mm

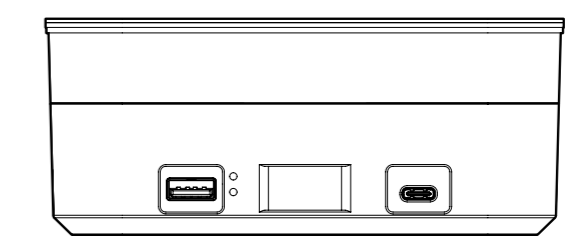
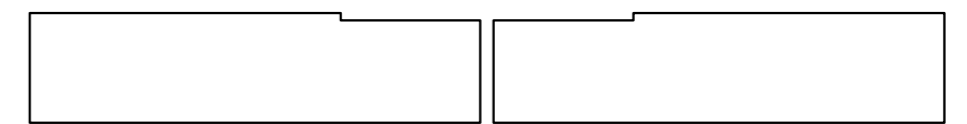



# EMBEDDED PACK

BATTERY PACK **FAST CHARGING**

PARK NUMBER : **IPN-BPV2/EMB**

## PRODUCT DESCRIPTION

A battery charger for phones and other mobile devices, which is fitted in the furniture. The Embedded antenna is housed in a cavity under the furniture top. The furniture maintains its original appearance. Marking the surface of the top is required.

## FEATURES



Marking on the surface

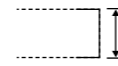

Top thickness from **12 to 80 mm**

## TECH SPECS

- Model number: IPN-BPV2
- FCC ID : 2A06R-IPN-BPV2
- Safe: overheating, overcurrent, overvoltage and short circuit protection
- Type: Wireless & USB (type A & type C) chargers on battery
- Charges: Up to 4 devices
- Outputs: USB-A : 18W Max, USB-C: Power Delivery 27W Max, DC-OUT : 24W Max.
- Inputs: DC-IN : 18W Max, USB-C : Power Delivery 27W Max
- Qi Wireless Charging: wireless charger works with all Qi compatible devices
- Pack dimensions (LxWxH): 22 x 11 x 13,5 cm
- Pack net weight: 900 gr

## WHAT'S IN THE BOX

- Embedded antenna
- Table Dock
- Lithium-ion Battery (71 Wh)

*Magnetic security key and Charging Tray sold separately.*

## CERTIFICATIONS

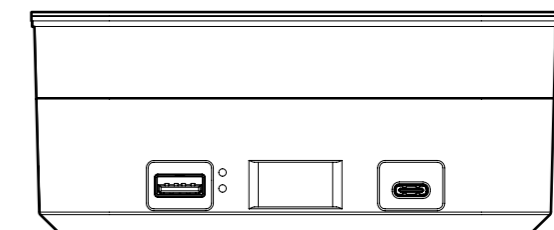
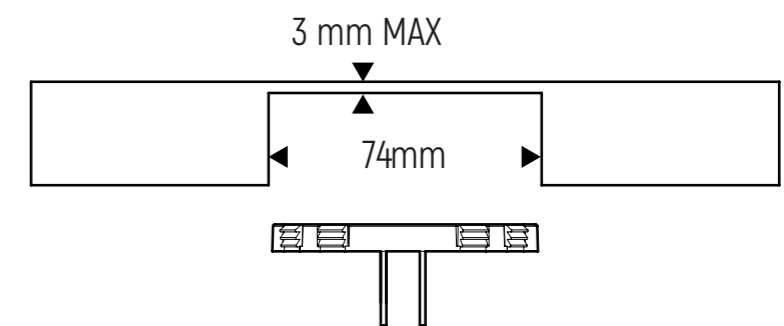
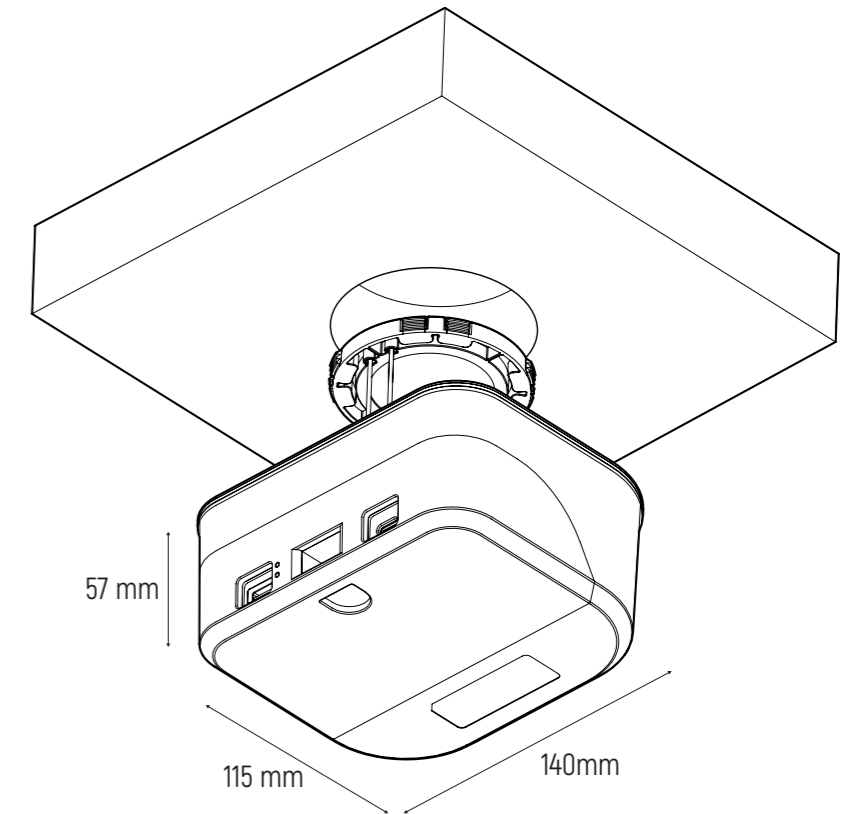



# USB PACK

BATTERY PACK **FAST CHARGING**

PARK NUMBER : **IPN-BPV2/USB**

## PRODUCT DESCRIPTION

The first autonomous & secure USB charging station. With the USB pack, the charging unit can be easily installed under any table without any machining on the table top.

## FEATURES



Installation in **5mn**



Adhesive fastening **ultra-resistant**

## TECH SPECS

- Model number: IPN-BPV2
- FCC ID : 2A06R-IPN-BPV2
- Safe: overheating, overcurrent, overvoltage and short circuit protection
- Type: USB (type A & type C) chargers on battery
- Charges: Up to 4 devices
- Outputs: USB-A : 18W Max, USB-C: Power Delivery 27W Max, DC-OUT : 24W Max.
- Inputs: DC-IN : 18W Max, USB-C : Power Delivery 27W Max
- Pack dimensions (LxWxH): 22 x 11 x 13,5 cm
- Pack net weight: 800 gr

## WHAT'S IN THE BOX

- Table Dock
- Lithium-ion Battery (71 Wh)

*Magnetic security key and Charging Tray sold separately.*

## CERTIFICATIONS

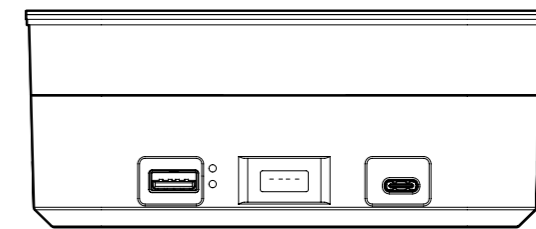
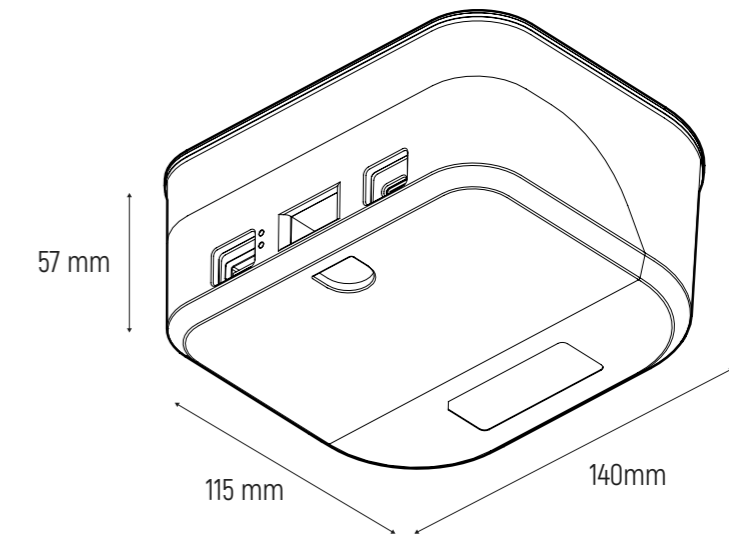



# CHARGING TRAY

PARK NUMBER : **IPN-INT-CT (EU / UK / US)**

## PRODUCT DESCRIPTION

The Charging tray allows you to recharge the batteries of the Battery Pack. Up to 4 batteries simultaneously in 3 hours.

## TECH SPECS

- Model number: IPN-INT-CT ▪ FCC ID : 2A06R-IPN-WDCK
- Pack dimensions (LxWxH): 31 x 19,5 x 10 cm ▪ Pack net weight: 1,40 Kg

## WHAT'S IN THE BOX

- Charging tray with 4 slots battery charger
- ACDC (84W max.) with EU or UK or US plug (according to the version chosen)

## CERTIFICATIONS



# MAGNETIC SECURITY KEY

PARK NUMBER : **IPN-INT-KEY**

## PRODUCT DESCRIPTION

The Magnetic Security Key is a handle which allows for unlocking and removal of the battery from the Battery Pack attached to the underside of the table.

## TECH SPECS

- Model number: IPN-INT-KEY
- Pack dimensions (LxWxH): 18,5 x 5,5 x 2 cm ▪ Pack net weight: 50 gr

## WHAT'S IN THE BOX

- Magnetic Security key

## BATTERY PACK **FAST CHARGING**

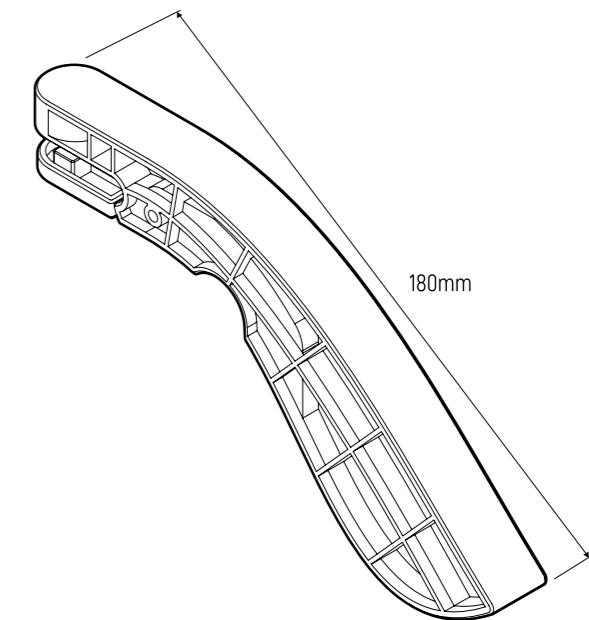
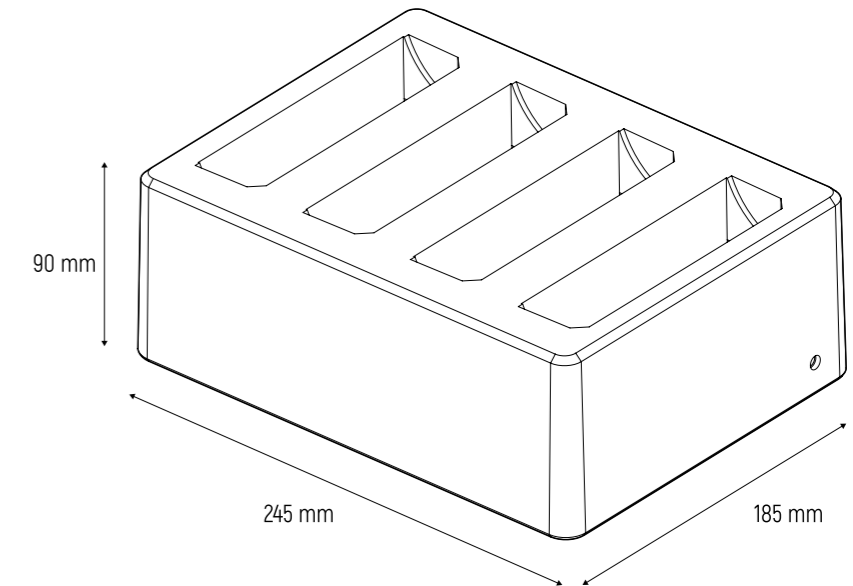

**IPANIPAN®**  
www.ipanipan.com

---

**FOLLOW US**

Scan Qr code or click on the button «linktree»

