



**PHARMATHEK**

AUTOMATION TECHNOLOGIES

**SINTESI**

The evolution of automation  
in pharmacy

**The 3<sup>rd</sup> generation of SINTESI.**



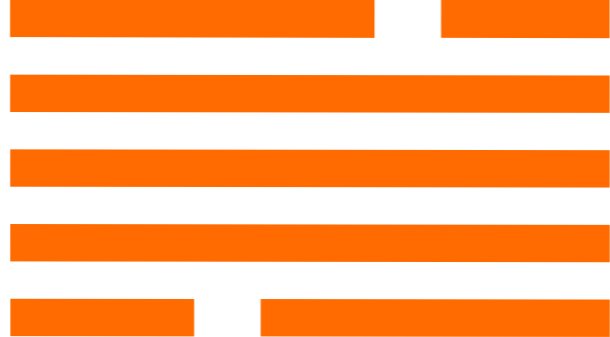

# PHARMATHEK

Since 2007, Pharmathek has been pioneering the best technologies of automated warehouses dedicated to drug management in pharmacies. Flexibility, speed and capacity are SINTESI's core values, now in its 3<sup>rd</sup> generation.



**15+**  
Years of experience

**800+**  
Global installations

**100%**  
Customisable

# SINTESI

Ergonomic, personal, elegant.

SINTESI integrates seamlessly into the environment, brings operational efficiency and enhances the work of the pharmacy team.

## COMPACT

Slim and modular, SINTESI makes the best use of the height, rather than the floor area of the pharmacy.

## CONFIGURABLE

SINTESI is always custom-designed.

## 100% AUTOMATIC LOADING

Pharmaload's exclusive RDE service reads 100% of the expiration dates.

## FAST

As an artificial intelligence, STRATEGA optimizes gripper paths. The result? Quick and efficient delivery of products.



## MAXIMUM CAPACITY

Deeper shelves than the industry average. Up to 4.366 items/meter.

## GRIPPERS UP TO 5 TIMES MORE EFFICIENT

The Euclid3D® is the only gripper with an integrated storage system. Carries up to 15 boxes at a time.

## ORDER AND TRACKING

CONNECTED EXIT tracks deliveries and simplifies dispensing at the counter. No more errors.

## PREDICTIVE MAINTENANCE

SINTESI is always connected to Pharmathek laboratories: we anticipate and plan maintenance sessions with you in advance to ensure the pharmacy remains operational.



## STRATEGA - AI

Developed by Pharmathek's R&D department, it analyzes pharmacy sales data, studies them and chooses which items to place close together on the shelves because they are often delivered together.



## SLIM-FIT

Fast, compact, silent.

Slim-Fit is the electromechanical gripper that maximises SINTESI's capacity.

### Advantages:

- Silent electromechanics
- 360° rotation
- Multi-picking (multi-product picking)
- Laser scanner that prevents errors on shelves
- Efficient, light weight with minimum power consumption

### 2 CONFIGURATIONS

SINGLE

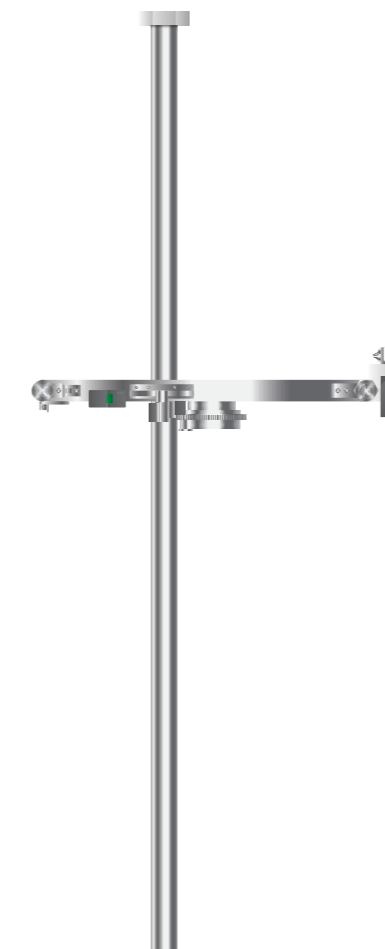

DOUBLE





## EUCLID3D

Innovative, unique, high-performance.

Euclid3D is the only gripper equipped with temporary storage for packages. It reduces up to 5 times the number of movements needed to manage orders.

### Advantages:

- All with Slim-Fit design
- 5 fewer movements per order (on average)
- Capacity: up to 15 boxes
- Multi-Mix picking (multi-packaging)

### 2 CONFIGURATIONS

SINGLE



DOUBLE

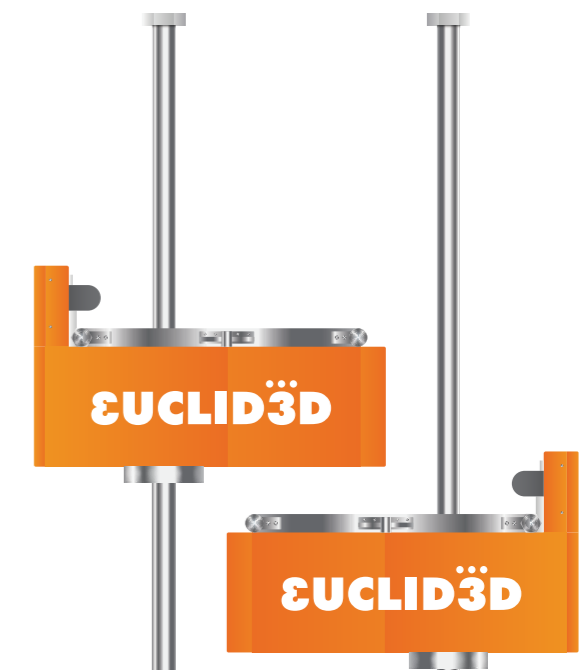



## EUCLID3D

The secret is out.

The Euclid3D is the only gripper that can pick up a package in any row with a single movement. How does it do it? By repositioning packages that are not a priority without having to make an intermediate delivery, unlike other systems.

No delivery splits means more time saved.

1

**Takes the whole row of boxes**

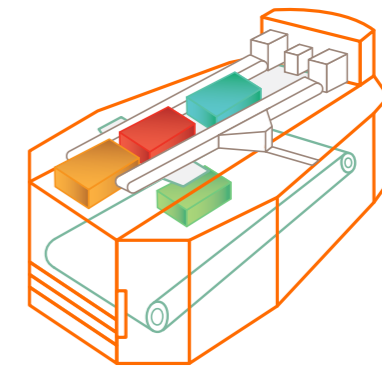

2

**Drops the box into the tank**

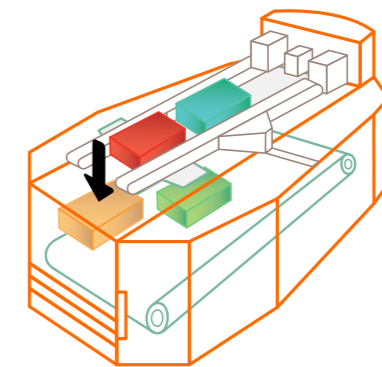

3

**Repositions the other boxes**

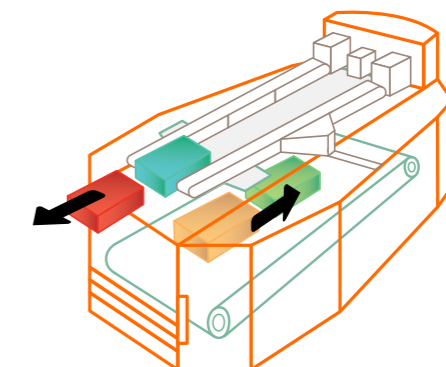

# PHARMALOAD

100% automated.

It can analyse, measure and load 4 boxes simultaneously. Fully electromechanical, Pharmaload is the assembly line for your warehouse.

## Advantages:

- 4 products at a time
- Up to 300 items per hour
- 100% of expiry dates are visible thanks to RDE
- X-Load hopper for large loads
- Checks transportation documents
- Reliability tested, pushes products rather than lifting them
- Max weight of 1 kg/Item



### REMOTE DATA ENTRY

This is the service that ensures that expiry dates are entered when they are not recognised by the OCR system.



### X-LOAD

This is the oversized loading hopper that holds thousands of boxes during the sorting phase.

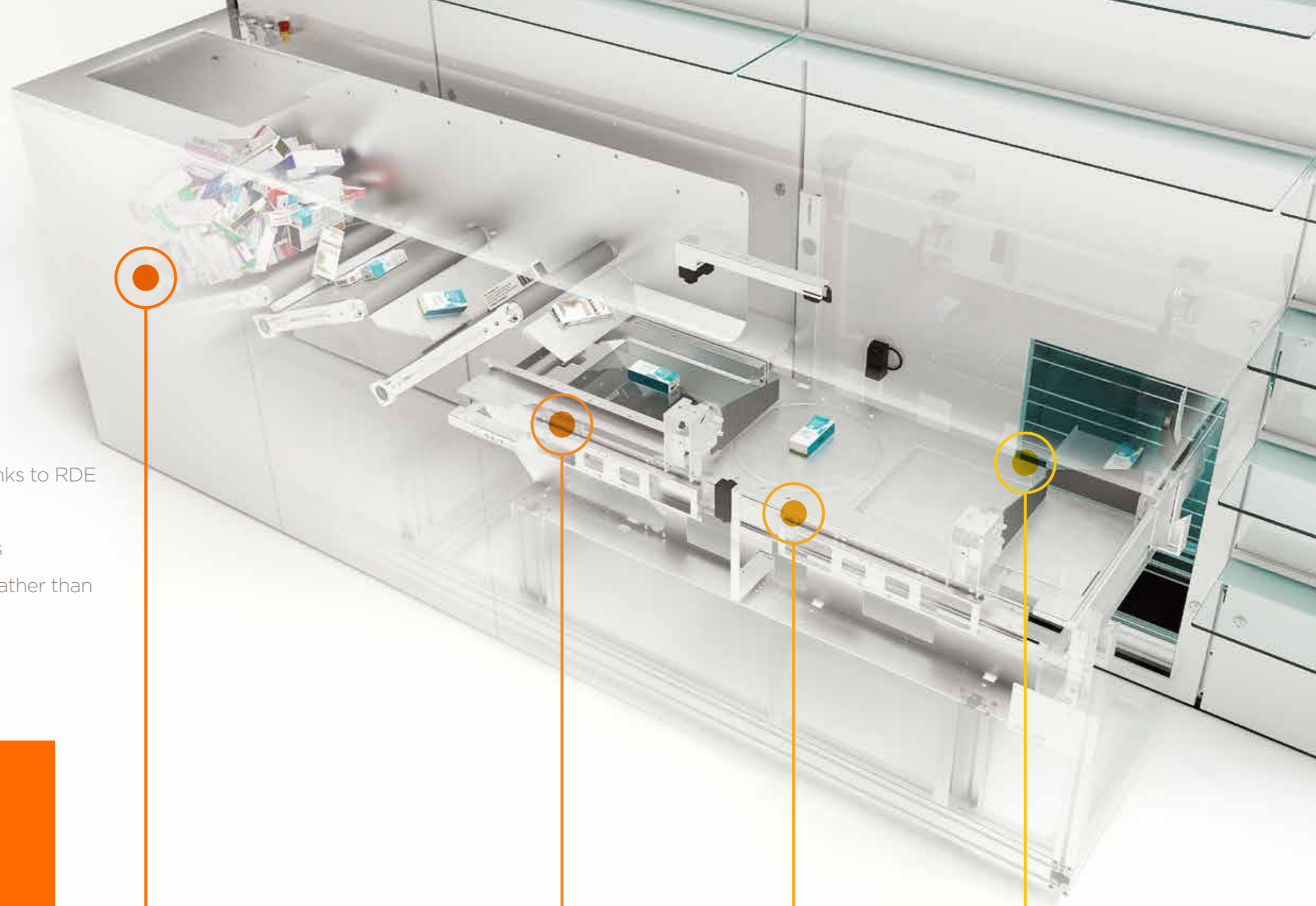

1

### Sorting

PHARMALOAD is self-sufficient: it takes care of the sorting of the individual boxes that are placed into the hopper.

2

### Analysis

Scans and checks the integrity and conformity of the dimensions of the box.

3

### Ability to read

Thanks to the turntable, the box is oriented to take more scans and to read the expiry date.

4

### Loading

The box is moved and positioned in the loading area.



# GEMINI

Redefines usability.

GEMINI applies the concepts of ergonomics to the software: **mobile interface, 22" vertical monitor, multi-touchscreen, customised dashboards** and **remote access** are features of GEMINI which simplify the way the pharmacist work.

## SELF-EXPLANATORY

GEMINI feels familiar, like using an app on a tablet and very user friendly.

## CUSTOMISABLE DASHBOARD

Create your own personal dashboard with the information you want to display in the front row.

## EXTRA-LARGE MONITOR

All the convenience of a large, bright 22" multi-touch vertical monitor.

## INTEGRATED

The software communicates with all other pharmacy management systems. The stock is shown in real-time.

## REMOTE ACCESS

GEMINI can replicate the control panel on any device in the pharmacy, giving you the ability to query, correct, recall products, etc.



# CUSTOMISATIONS

A SINTESI robot that's completely your own.

Conveying an image that is consistent with our values is a fundamental objective for contemporary pharmacy. This is why Pharmathek offers customisable materials, colours and communication features, allowing you to enhance the aesthetic of the SINTESI robot in the eyes of customers or to integrate it seamlessly into its environment.

## MATERIALS

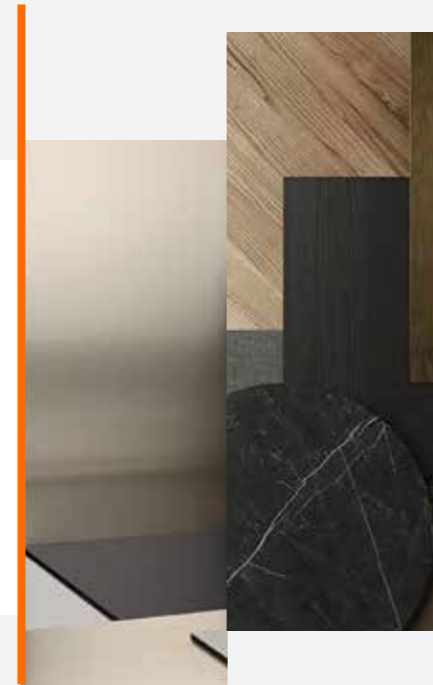

A catalogue that goes beyond veneered wood: discover textured effects, such as wood with grain or textured fabrics.

## COLOURS



Brilliant, sophisticated, subtle and minimal. SINTESI has an array of colours to choose from so that you can identify the most suitable shade for your pharmacy's décor. The **LightYou™** coloured interior lighting adds even more personality.

## COMMUNICATION

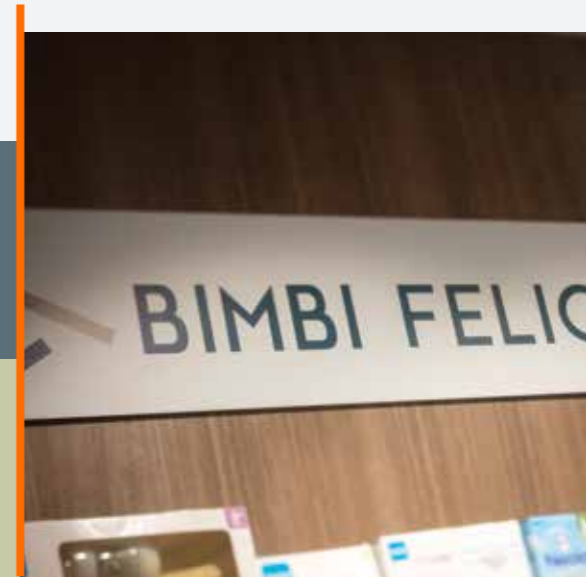

Covers a SUMMARY of graphic elements. **Magnetic Skin®** is an innovative printable material, easily replaceable over time, that updates your robot in the pharmacy.

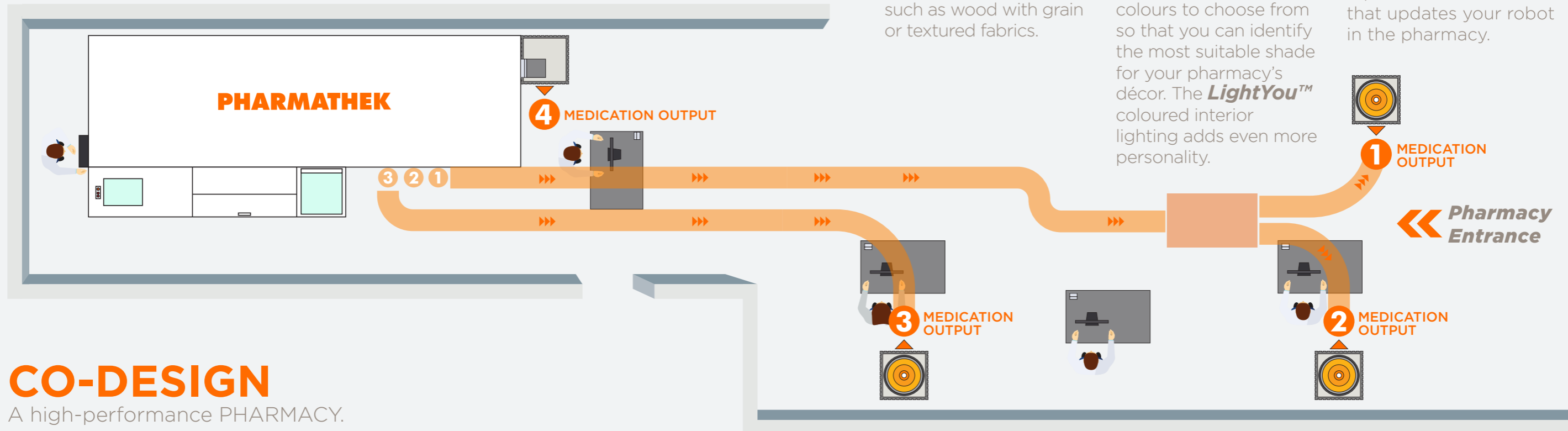

# CO-DESIGN

A high-performance PHARMACY.

Pharmathek's method for identifying the best warehouse automation consists of three stages: analysis, consultancy, planning. The objective? Tailor the SINTESI robot to each pharmacy, capable of adapting to the space and product delivery requirements, with specially designed outlets and transfers.

## ANALYSIS

## CONSULTANCY

## DESIGN

## CONNECTED EXIT

The intelligent outlet assists the pharmacist.

Enables the benefits of connectivity right up to the point of product delivery.

Connected Exit provides the best possible organisation for shared exits between pharmacists, safeguarding them from errors, missing or mistaken medication.

### TRACE THE MEDICATION

It allows you to know which medicine has been delivered in a given order.

### ORGANISE YOUR WORKLOAD

Arrives at service stations with ease and utilises shared exits between pharmacists.

### AVOID ERRORS

It does not allow orders to be processed while incomplete or with products intended for other patients.

### ELIMINATES STRESS

The pharmacist's focus is on the patient, not on monitoring the machine.

## DEDICATED FEATURES AND SERVICES

SINTESI is always connected.

## ASSISTANCE

At Pharmathek there is always a technician available to support you.

## VIDEO SURVEILLANCE

The video surveillance system helps in the understanding of requests for assistance. Every movement is digitally recorded to alert the service team of even the slightest irregularity and allow for a timely resolution.

## PERSONAL REPORTS

Easy-to-read charts and tables give you real-time information on the status and possible modifications that can aid warehouse management.

## PREDICTIVE MAINTENANCE

Monitoring and control is the key to anticipating any abnormalities. Through data analysis, we plan maintenance work to ensure that the pharmacy is always operational.

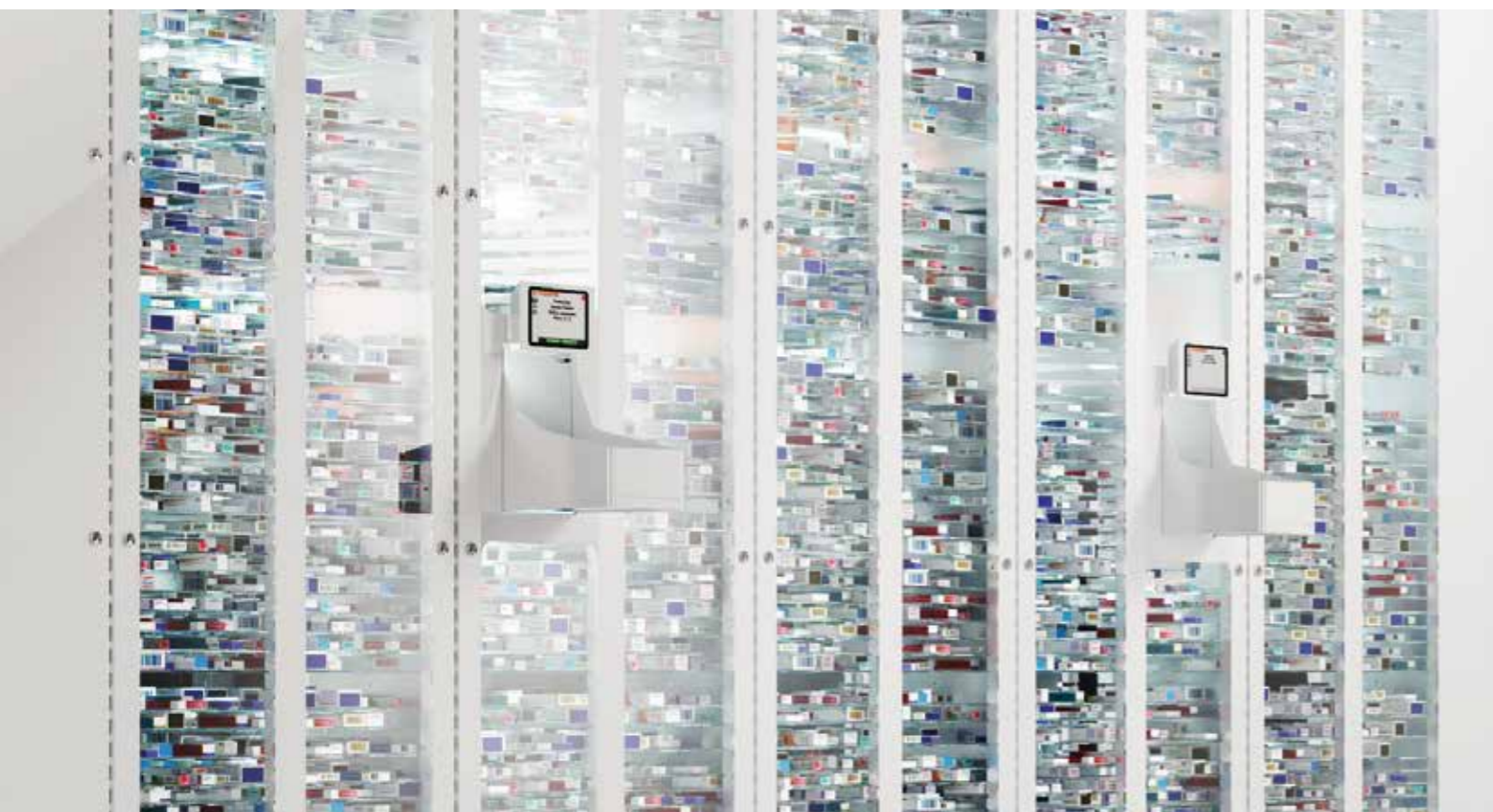

# VERSATILITY

A project for every pharmacy.



## LENGTH from 3m to 15m, HEIGHT from 2m to 4m, WIDTH 1.43m:

SINTESI's modular dimensions allow the robot to fit into any pharmacy space. Custom modifications can be designed. SINTESI is the most compact robot in its field.



### ACCESS DOOR:

The access door of the SINTESI robot, which can be positioned on its short or long sides, can be placed in the most convenient location for the pharmacist.



### OPERATOR WORKSTATION:

The operator's station can be located at the four corners of SINTESI, on the short or long sides. This way, the pharmacist has the greatest freedom to choose the optimum operating position.

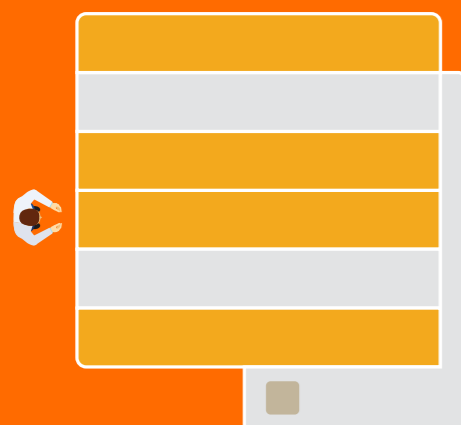

### MULTI-SYSTEM FOR LARGE VOLUMES:

For high capacity and speed requirements, two or more machines can be combined to share the automatic loader for optimal product distribution.

<b>DIMENSIONS</b>	height	2,00 - 4,00 m
	length	3,00 - 15,00 m
	depth	1,43 m
<b>POTENTIAL CAPACITY</b>	min	3.300 pieces
	max	65.500 pieces
<b>WEIGHT SQM UNLOADED</b>	min	251 kg
	max	663 kg
<b>AVERAGE NOISE OUTPUT</b>	50,5 db (A)	

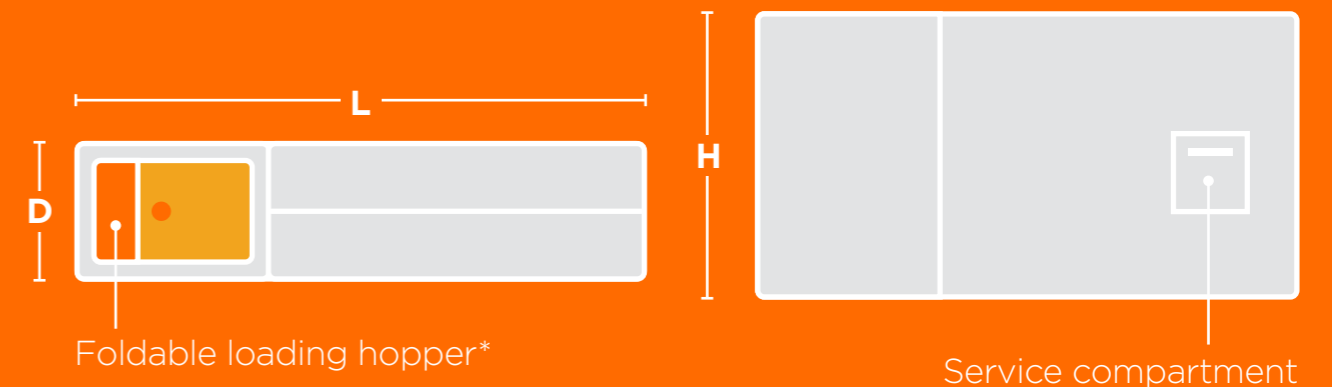

Foldable loading hopper\*

Service compartment

**H:** 1.000 mm

**D:** 650 mm

**L:** 2.700 mm

*\*Possibility to configure XLoad loading hopper with extended loading capacity.*

### PHARMALOAD AUTOMATIC LOADER

The automatic loading process starts by emptying the medicine box into the foldable loading hopper. The system then automatically sorts the items, reads the expiry date, places the products on the shelves and ticks it off as completed.

### PHARMATHEK EXCLUSIVE:

RDE (Remote Data Entry) service, integrated service for entering unread expiry dates automatically.

PATENT  
**PHARMATHEK**



**PHARMATHEK**

AUTOMATION TECHNOLOGIES

**HQ ITALY**

**VERONA**

Via Enrico Fermi 43  
37136 Verona  
+39 045 950301  
info@pharmathek.com  
[www.pharmathek.com](http://www.pharmathek.com)

**FRANCE**

Allée de Saint Cloud, 5  
54600 Villers les Nancy

**SPAIN**

Carrer Pagesia, 22-24  
08191 Rubi (Barcelona)

**GERMANY**

Bernburger Straße 32  
10963 Berlin